

PLAT OF SURVEY

LOT 1, CERTIFIED SURVEY MAP NO. 4525, BEING A PART OF LOT 61 AND ALL OF LOT 62, IN SHOREWOOD SUBDIVISION, LOCATED IN PART OF THE SOUTHWEST 1/4 OF THE SOUTHEAST 1/4 OF SECTION 10, TOWN 4 NORTH, RANGE 18 EAST, IN THE TOWN OF EAST TROY, WALWORTH COUNTY, WISCONSIN.

SURVEYED FOR: RUEBL BUILDERS/ARMBRUSTER
SURVEY ADDRESS: W1042 SHOREWOOD DRIVE

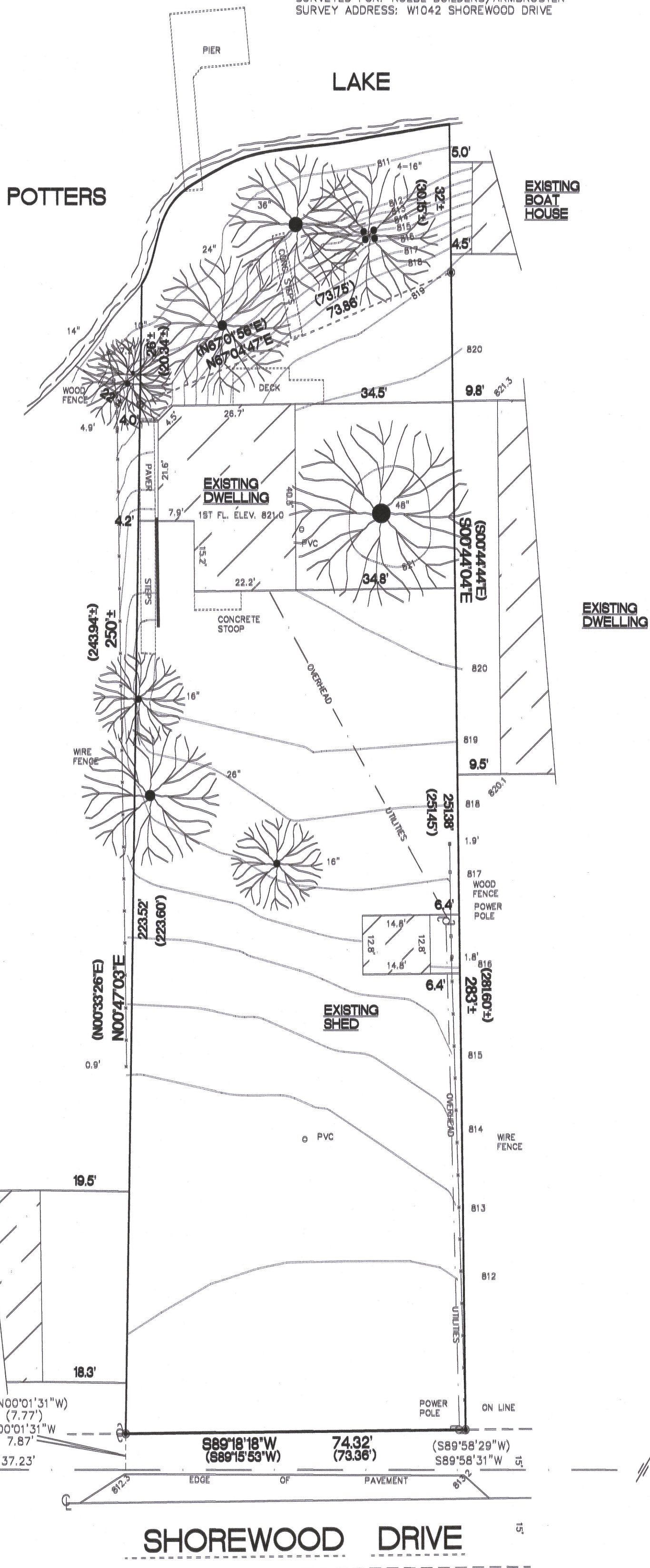

EXISTING IMPERVIOUS SURFACE AREAS

DWELLING FOOTPRINT: 1075 SQ. FT.
SHED FOOTPRINT: 189 SQ. FT.
CONCRETE: 97 SQ. FT.
PAVERS: 150 SQ. FT.
DECK: 135 SQ. FT.

TOTAL: 1646 SQ. FT.

LOT AREA: 19532± SQ. FT.

8.4% DENSITY

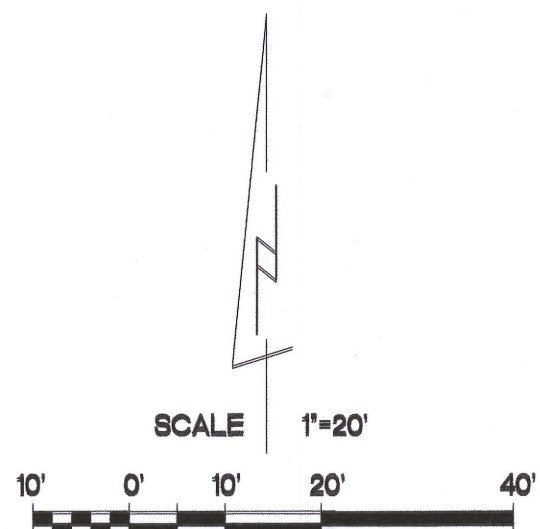

BEARINGS ARE REFERENCED TO THE SOUTH LINE OF THE SOUTHWEST 1/4 OF SECTION 10-4-18 AND IS ASSUMED TO BEAR S89°58'29\"/>

EAST WITNESS CORNER OF THE SOUTHWEST CORNER OF THE SOUTHEAST 1/4 OF SECTION 10-4-18

SOUTHEAST CORNER OF THE SOUTHWEST 1/4 OF SECTION 10-4-18

- FOUND 6" CONC. MON. W/BRASS CAP
- FOUND 1 1/4" O.D. IRON PIPE
- FOUND 3/4" O.D. IRON PIPE
- EXISTING SPOT ELEVATIONS
- () RECORDED AS DIMENSIONS



I hereby certify that I have surveyed the above property and that the above map is a true representation thereof and shows the size and location of the property, its exterior boundaries, the location of all visible structures and dimensions of all principal buildings thereon, boundary fences, apparent easements, roadways and encroachments if any.

"This survey is made for the use of the present owners of the property, and also those who purchase, mortgage or guarantee the title thereto within one year from date hereof."

THIS IS NOT AN ORIGINAL SURVEY UNLESS THE SEAL IS PRESENT

6/9/2020 DATE TEP FIELD WORK BY TEP DRAWN BY 20058 JOB NUMBER

Kettle Moraine Surveying Inc.
P.O. Box 357
Eagle WI. 53119
(262)594-3484
kettlemorainesurveying.com