

PREPARED FOR  
SISTERS OF THE RESURRECTION  
7432 TALCOTT AVE  
CHICAGO, ILL. 60651

PATHFINDER SURVEYING INC.  
6400 W. 111th St.  
J.K. SURVEYING INC.  
P.O. BOX 322  
LAKE GENEVA, WI. 53147  
WWW.PATHFINDERSURVEYING.NET  
262-248-8303

# PLAT OF SURVEY

OF  
THE WEST 25 FEET OF LOT 4 AND LOT 5, METTOWEE SUBDIVISION, LOCATED IN SECTIONS 28 AN 33,  
TOWN 2 NORTH, RANGE 16 EAST, TOWN OF DELAVAN WALWORTH COUNTY, WISCONSIN,  
TOGETHER WITH THE MORE OR LESS 15 FEET OF VACATED DELAVAN AVE LYING SOUTHERLY AND  
ADJACENT TO THE ABOVE DESCRIBED PARCEL.

FMT 00002

LOT 6 AND THE EAST 25.0 FEET OF LOT 7, METTOWEE SUBDIVISION, LOCATED IN SECTIONS 28 AN 33,  
TOWN 2 NORTH, RANGE 16 EAST, TOWN OF DELAVAN WALWORTH COUNTY, WISCONSIN,  
TOGETHER WITH THE NORTHERLY 15 FEET OF VACATED DELAVAN AVE LYING SOUTHERLY AND  
ADJACENT TO THE ABOVE DESCRIBED PARCEL.

FMT 00004

LOT 19 AND THE WEST 25.0 FEET OF LOT 20, METTOWEE SUBDIVISION, LOCATED IN SECTIONS 28 AN 33,  
TOWN 2 NORTH, RANGE 16 EAST, TOWN OF DELAVAN WALWORTH COUNTY, WISCONSIN,  
TOGETHER WITH THE NORTHERLY 15 FEET OF VACATED DELAVAN AVE LYING NORTHERLY AND  
ADJACENT TO THE ABOVE DESCRIBED PARCEL.

FMT 00008

THE EAST 25.0 FEET OF LOT 17 AND LOT 18, METTOWEE SUBDIVISION, LOCATED IN SECTIONS 28 AN 33,  
TOWN 2 NORTH, RANGE 16 EAST, TOWN OF DELAVAN WALWORTH COUNTY, WISCONSIN,  
TOGETHER WITH THE MORE OR LESS 15 FEET OF VACATED DELAVAN AVE LYING NORTHERLY AND  
ADJACENT TO THE ABOVE DESCRIBED PARCEL.

FMT 00007

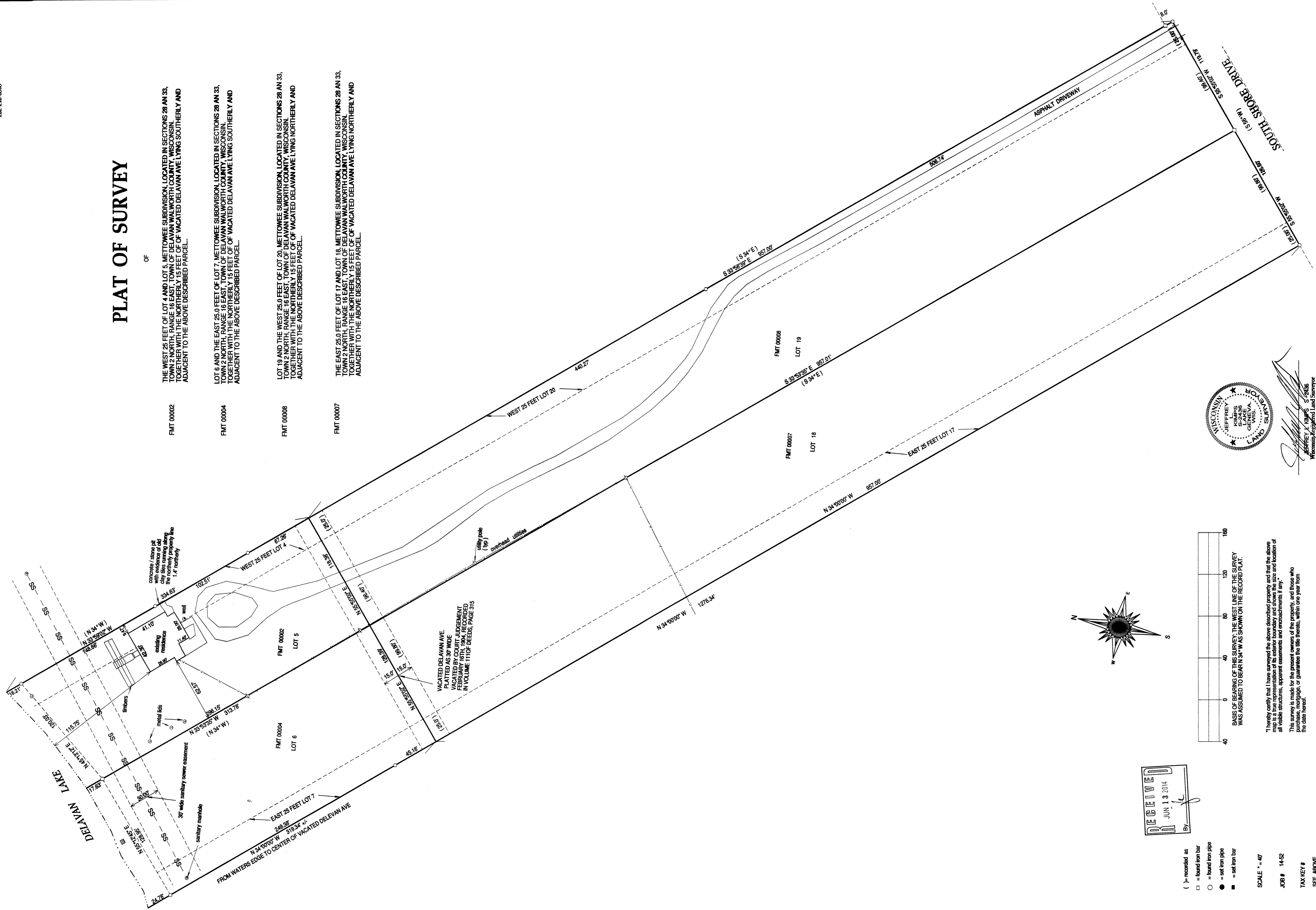

RECEIVED  
JUN 13 2014

- ( ) - recorded as
- - found iron bar
- - found iron pipe
- - set iron pipe
- - set iron bar

SCALE \* = 40'  
JOB # 14-52  
TAX KEY #  
SEE ABOVE

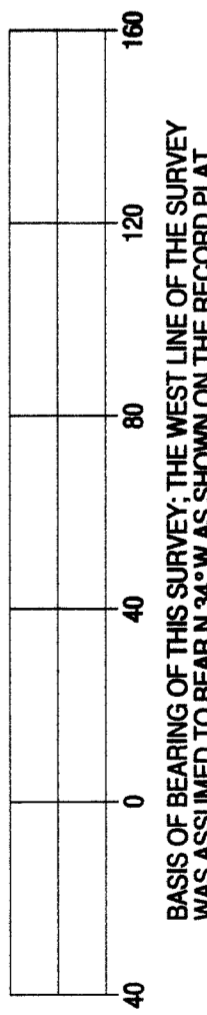
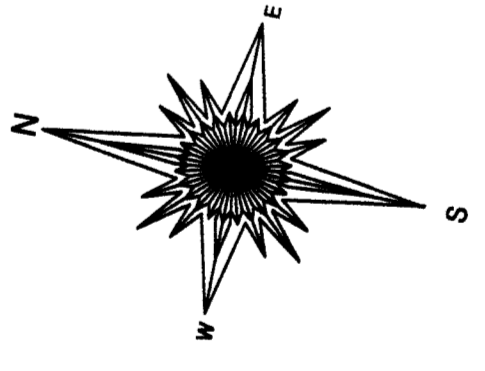

BASED ON READINGS OF THIS SURVEY, THE WEST LINE OF THE SURVEY WAS ASSUMED TO BE AN 34'-W AS SHOWN ON THE RECORDED PLAT.

"I hereby certify that I have surveyed the above described property and that the above map is a true representation of its exterior boundary and shows the size and location of all visible structures, apparent easements and encroachments if any."  
This survey is made for the present owners of the property, and those who purchase, mortgage, or guarantee the title thereto, within one year from the date hereof.

DATED THIS 10TH DAY OF APRIL, 2014

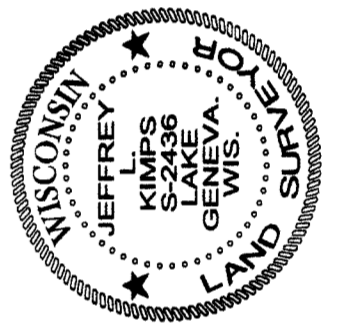

*Jeffrey J. Kivins*  
JEFFREY J. KIVINS, S 29436  
Wisconsin Registered Land Surveyor  
(original if signed in red)

FMT - 2  
FMT - 4  
FMT - 7  
FMT - 8  
216-5101