

PLAT OF SURVEY

LEGAL DESCRIPTION:

A PARCEL OF LAND LOCATED IN THE NORTHWEST 1/4 OF THE NORTHWEST 1/4 OF SECTION 29 IN TOWNSHIP 2 NORTH, IN THE TOWN OF GENEVA, WALWORTH COUNTY, WISCONSIN. MORE PARTICULARLY DESCRIBED AS: UNIT 15-41 OF GENEVA NATIONAL CONDOMINIUM NO. 15. SAID CONDOMINIUM PLAT BEING DULY RECORDED ON MAY 25TH 1990, IN THE OFFICE OF THE REGISTER OF DEEDS FOR WALWORTH COUNTY, IN VOLUME A, ON PAGE 64, AND AS DOCUMENT NO. 194633.

NORTHWEST CORNER OF LOT 15-42, GENEVA NATIONAL CONDOMINIUM NO. 15

SOUTHWEST CORNER OF LOT 15-40, GENEVA NATIONAL CONDOMINIUM NO. 15

LOT 15 - 41
 GENEVA NATIONAL CONDOMINIUM NO. 15
 TAX KEY NO. JGN 1500041
 19,772.80 S.F. ±
 0.45 ACRES ±

SOUTHEAST CORNER OF LOT 15-42, GENEVA NATIONAL CONDOMINIUM NO. 15

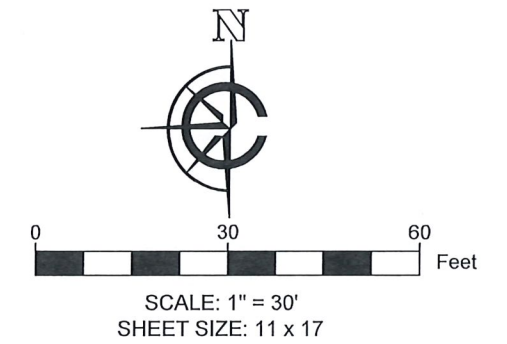

LEGEND

- EXISTING ASPHALT
- U FOUND UTILITY PEDESTAL
- E FOUND ELECTRIC PEDESTAL
- MH FOUND MANHOLE
- wv FOUND WATER VALVE
- (xx) RECORDED AS
- FOUND IRON ROD
- SET 1" I.D. IRON PIPE 18", 1.13# L.F.

BASIS OF BEARING:

THE WISCONSIN STATE PLANE COORDINATE SYSTEM, SOUTH ZONE, NAD-83 (2011).

THE SOUTH LINE OF LOT 15-41, GENEVA NATIONAL CONDOMINIUM NO. 15 ASSUMED TO BEAR N53°37' 57"W.

SURVEY ORDERED BY:
EDWARD FRANKE

TAX KEY:
JGN 1500041

FIELD WORK COMPLETED ON:
MARCH 9, 2026

FIELD CREW CHIEF:
LUKE LILLA

SURVEYOR:
MICHAEL J. MARTIN, PLS
CARDINAL ENGINEERING LLC



I, MICHAEL J. MARTIN, PLS-2307, HEREBY CERTIFY THAT I HAVE SURVEYED THE ABOVE DESCRIBED PROPERTY AND THAT TO THE BEST OF MY KNOWLEDGE AND BELIEF THE ABOVE MAP OR PLAT IS A TRUE AND CORRECT REPRESENTATION THEREOF AND SHOWS THE SIZE AND LOCATION OF ALL VISIBLE STRUCTURES AND DIMENSIONS OF ALL PRINCIPLE BUILDINGS THEREON; BOUNDARY FENCES, APPARENT EASEMENTS, ROADWAYS, AND VISIBLE ENCROACHMENTS IF ANY.

THIS MAP OR PLAT AND THE SURVEY ON WHICH IT IS BASED WAS PREPARED IN ACCORDANCE WITH CHAPTER A-E.7 "MINIMUM STANDARDS FOR PROPERTY SURVEYS" OF THE WISCONSIN ADMINISTRATIVE CODE AND IS MADE FOR THE EXCLUSIVE USE OF THE PRESENT OWNER(S) OF THE PROPERTY AND ALSO FOR THOSE WHO PURCHASE, MORTGAGE, OR GUARANTEE TITLES THERETO WITHIN ONE(1) YEAR FROM THE DATE HEREOF.

mj. martin 03-11-26
 MICHAEL J. MARTIN, PLS #2307 DATE

CURVE DATA				
CURVE NUMBER	LENGTH (FT)	RADIUS (FT)	CHORD BEARING	CHORD DISTANCE
C1	52.89	633.70	S64° 18' 24"E	52.87
C2	48.99	666.88	S64° 35' 36"E	48.98
(RECORDED CURVE DATA)				
CURVE NUMBER	LENGTH (FT)	RADIUS (FT)	CHORD BEARING	CHORD DISTANCE
C1	52.887	633.70	S64° 19' 31"E	52.871
C2	48.986	666.88	S64° 36' 42"E	48.975

CARDINAL
 PLAN | SURVEY | ENGINEER

526 S WELLS STREET,
 LAKE GENEVA, WI 53147
 262-757-8776
 PLANSURVEYENGINEER.COM

DATE: 03 / 11 / 2026 JOB No. 26167
 SHEET 1 OF 1 RAB