

PLAT OF SURVEY

-OF-

LOT 1, BLOCK 8, DELMAR SUBDIVISION, LOCATED IN THE SOUTHWEST 1/4 OF SECTION 27, TOWNSHIP 2 NORTH, RANGE 16 EAST, IN THE TOWN OF DELAVAN, WALWORTH COUNTY, WISCONSIN.

PREPARED FOR: SOUTHEASTERN WISCONSIN HOUSING CORP.

PROPOSED DWELLING WAS STAKED ON ACTUAL CORNERS WITH 5.00 FOOT CONTROL ON THE LONGEST HOUSE LINE. THE CONTRACTOR WILL BE RESPONSIBLE TO FIELD VERIFY ALL STAKES FOR LOCATION AND DIMENSION PRIOR TO CONSTRUCTION. IF ANY DISCEPANCIES ARE FOUND NOTIFY THIS OFFICE AT ONCE.

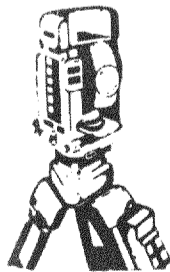
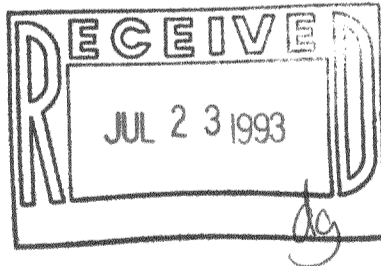
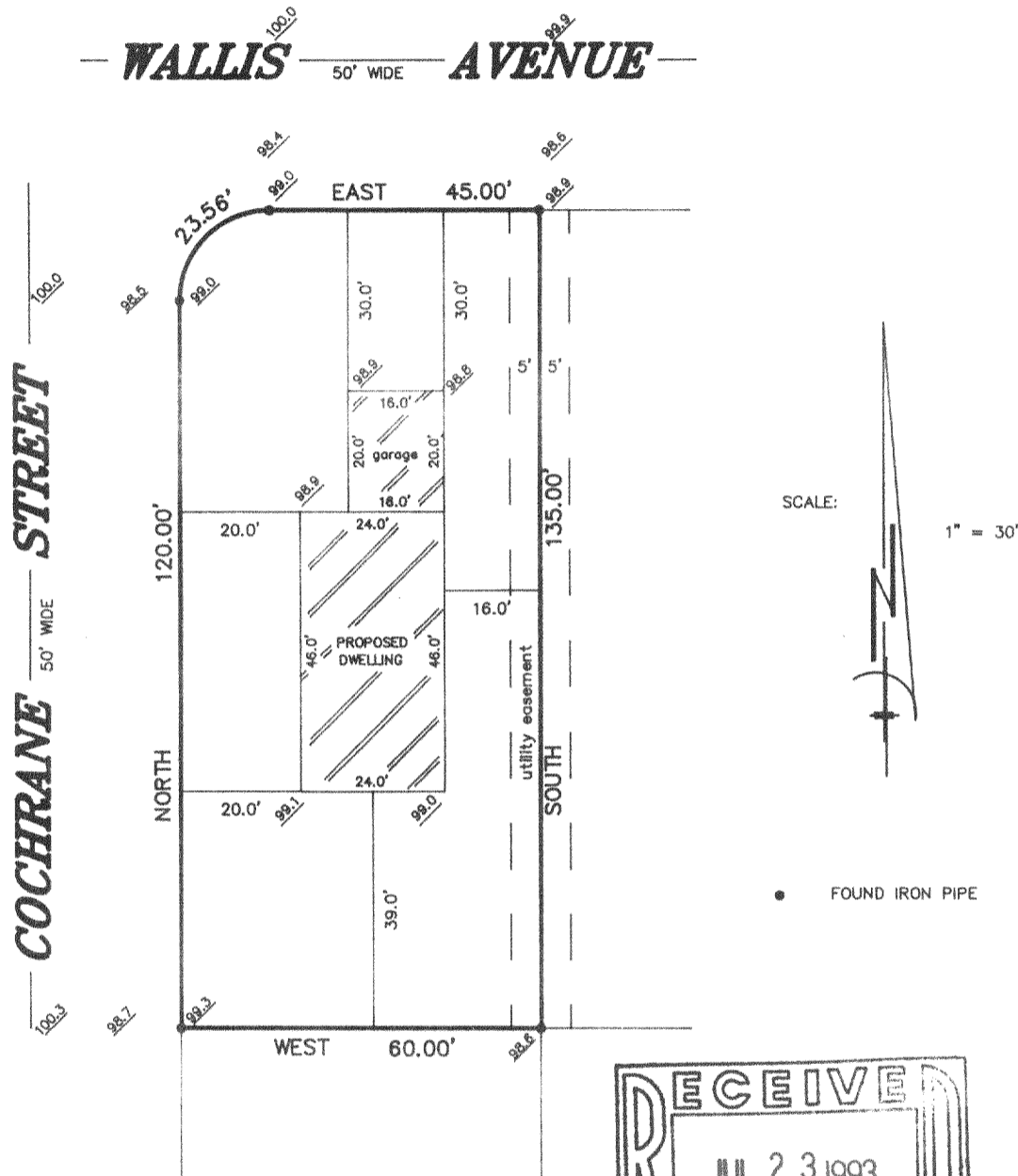

**B.W. SURVEYING**

Land Surveys  
Mapping And Planning  
35117 Academy Road  
Burlington, Wisconsin 53105  
(414) 534-4109

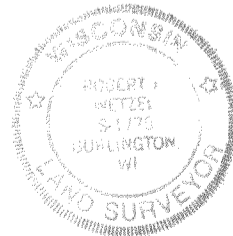

THIS IS NOT AN ORIGINAL PRINT  
UNLESS THIS SEAL IS RED

*Robert J. Wetzel*

ROBERT J. WETZEL  
REGISTERED LAND SURVEYOR - 1778

Revised: 3/8/93

3/1/93  
DATE

1062  
JOB NUMBER

"I hereby certify that I have surveyed the above described property and that the above map is a true representation thereof and shows the size and location of the property, its exterior boundaries, the location of all visible structures and dimensions of all principal buildings thereon, boundary fences, apparent easements, roadways and encroachments, if any."

"This survey is made for the use of the present owners of the property, and those who purchase, mortgage, or guarantee the title thereto within one year from date hereof."